

PHOTOMETER 2

Focal Plane Metering System

For

Large Format Photography

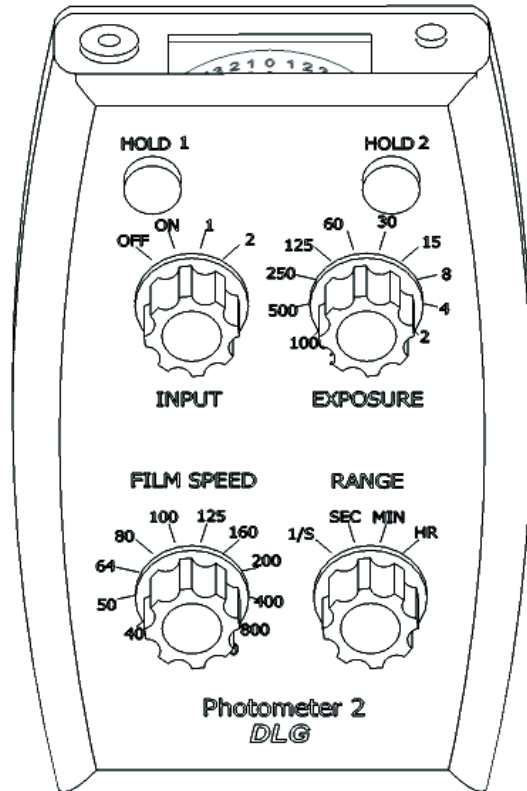

CONTENTS

Introduction.....	3
Introduction to Focal Plane Exposure Metering.....	4
Using the Photometer 2.....	5
Care of Your Photometer.....	10
Technical And Performance Data.....	11
Warranty, Servicing, Repairs and Enquiries.....	12
Specification.....	13

INTRODUCTION

Image-plane metering with a large-format camera allows brightness measurements to be taken at any desired point in the image. This allows exposure to be optimised taking into account shadow and highlight areas, ensuring that detail within these areas is captured in the negative. The Photometer 2 provides image-plane metering at an affordable price in a simple, easy-to-use and robust metering system.

The Photometer 2 comprises a metering unit, a frame (which is inserted in the camera in place of the film carrier) with integral metering probe, and a connecting lead.

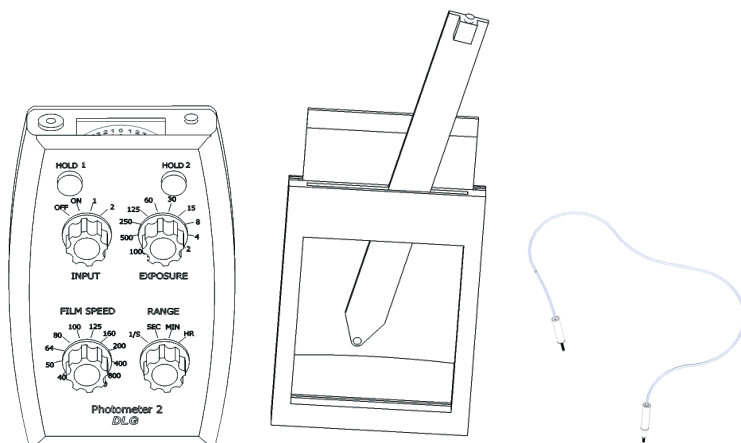

INTRODUCTION TO FOCAL PLANE EXPOSURE METERING

A photographic exposure meter measures lighting and indicates camera settings to give a nominally optimum exposure of the film. Several methods of metering are widely used.

Reflected Light Metering

Wide angle reflected light metering gives an overall reading of the luminance of the scene and will indicate camera settings such as to render the overall scene average luminance at a mid-grey level. This is the most common technique and gives good results with "normal" scenes. However, in an unbalanced scene, with a dominant dark or bright feature, the exposure may not favour the feature of interest. As an example, imagine a scene with the mouth of a cave in an otherwise brightly lit daylight scene. Using camera settings indicated by a wide angle reflected light meter will give an exposure optimised for the average across the scene including the dark cave interior and the brightly lit daylight outside. It is likely that the detail within the shadow of the cave will not be satisfactorily rendered, with the negative underexposed in this area and failing to show any detail within the cave shadows. Similar situations can arise when photographing dark objects against the sky, or in a snow scene, or when trying to photograph a brightly lit subject against a dark background.

Incident Light Metering

Incident-light metering partially addresses this issue by indicating an exposure setting based on the light falling on the subject of interest in the scene. In our cave example, an incident light reading could be taken within the cave in an attempt to optimise the exposure for the shadowed cave interior. However, the incident light reading obviously does not take into account the reflectivity of the subject.

Large-Format Focal Plan Metering

With large format photography, the possibility exists to measure the actual illumination at specific points in the image, and to optimise the exposure for features of interest in the image. Further, it is possible to measure the illumination at various points in the image where it is desired to get good rendering of shadow and/or highlight detail, and to optimise the exposure to achieve the best compromise. Furthermore, by determining the total range of luminance across the shadows and highlights of the image, the film processing may be optimised to give the best results.

The focal plan metering system lends itself to use of the Zone System, devised by Ansel Adams and Fred Archer. An excellent description of this system is given in Adams' book *The Negative (1981)*.

USING THE PHOTOMETER 2

Components of the Metering System

The metering system comprises:

1. The meter
2. Frame, including rear shutter.
3. Sensing probe
4. Connecting cable.

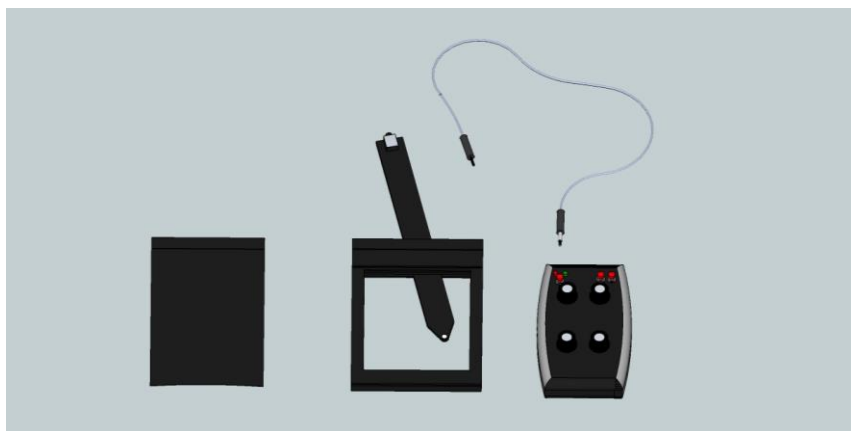

Insert 9V battery type - 6LR61 / 1604A / PP3. The battery compartment is on the rear of the case. The label inside the battery compartment indicates the polarity. The meter is designed with protection for reverse battery connection in case the battery is inadvertently inserted the wrong way round.

Insert the frame in the camera exactly as you would a film carrier. The metering frame is designed to the same geometry as a standard film carrier and should engage positively in the camera. The frame incorporates a slide shutter and this should be behind the metering probe, that is, it should come between the ground glass screen and the metering probe. The shutter is used to exclude light from the interior of the camera when taking readings particularly in challenging circumstances.

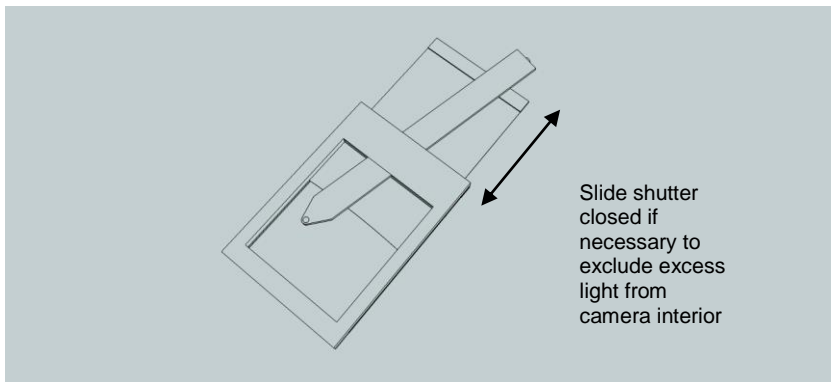

Insert the metering probe into the wider of the two slots in the top of the frame, if it is not already inserted. The sensor should be facing the front (lens) of the camera. If it is not clear which side is the sensor, the connector block at the other end of the probe should be on the front side. A white circle on the rear of the metering probe indicates the location of the sensor.

Connect the probe to the metering unit with the cable.



Turn on the meter and set the film speed (lower left control).

The display indicator will display zero (centre of the display) when the measured part of the image will give a neutral grey at the exposure settings on the meter.

Move the metering probe within the image to measure the brightness of the various features within the image. Adjust the "exposure" settings on the meter as required in order to keep the display within the required range. The display is marked in whole top

numbers, so that e.g. +1 on the display indicates a factor of two in the brightness and thus one additional f-stop on the lens aperture or one increment of exposure setting. Normally, features that are darker than 2-3 stops from the nominal will render as full black, with no additional detail therefore visible, and features 2-3 stops lighter than the nominal will render as white, likewise showing no further detail.

The meter incorporates two memories, which can hold the brightness value at two points in the image while metering a third. This is convenient when attempting to optimise the exposure across more than one feature in the image. When the “hold” buttons are pressed, the currently-metered brightness value is stored in the meter in the corresponding memory.

Turning the on-off-1-2 switch to the hold 1 or hold 2 positions displays the stored brightness.

A typical use might be as follows.

1. Measure the image brightness in a shadow area of interest. Adjust the exposure controls to give a reading of, say, two stops down from centre scale in order to give a dark rendering but still showing some details. Press the “hold 1” button to store this brightness.
2. Move the metering probe to measure a highlight feature. Adjust the “exposure” controls on the metering as required to bring this into the range of ± 3 on the display.
3. After setting the exposure control on the meter at step 2 above, turn the off-on-1-2 control to the “1” position and confirm that the previously-stored brightness in the shadow area is still within an acceptable range. If not, re-adjust the exposure settings to bring both the highlight area and the shadow area into an acceptable range.

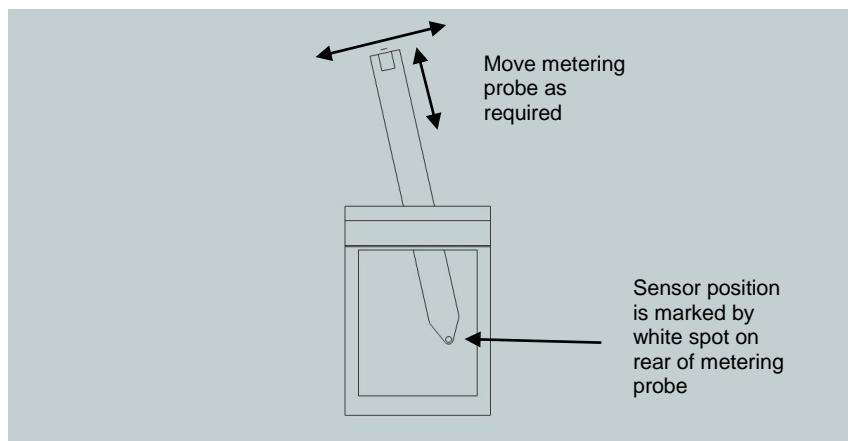

Description of the Controls and Display

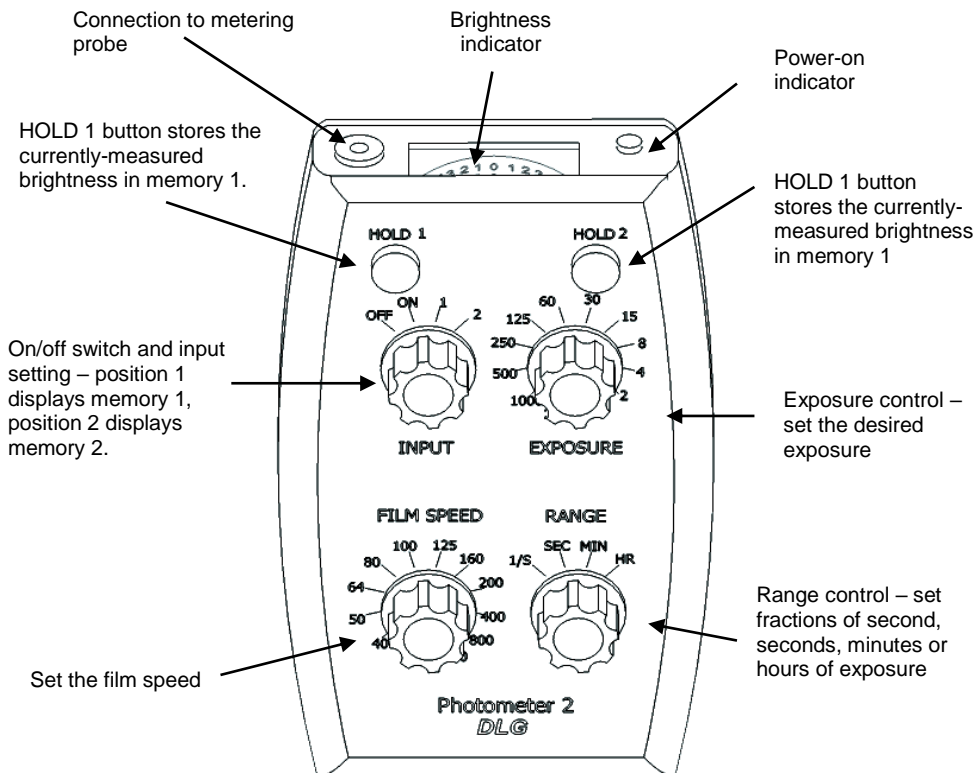

INPUT Control

Positions: "Off", "On", "Hold 1" and "Hold 2"

"Off" disconnects power and all functions.

"On" enables the meter. The meter responds to the light level on the sensor. The display indicates the brightness of the image relative to a notional 18% grey value for the selected exposure setting and film speed. Display pointer to the right indicates brighter whereas to the left indicates darker.

When either of the "HOLD" positions is selected, the corresponding stored value is displayed. The HOLD functions memorise the brightness not the display – the displayed value is adjusted according to the settings of the exposure, range and film speed settings.

EXPOSURE and RANGE control

Together these enable the exposure time to be selected. The maximum exposure is approximately 1 hour at 125 ASA.

At very low light levels the meter can take some time to respond and settle to an accurate reading. Avoid exposing the sensor to high brightness conditions immediately prior to taking readings at very low light levels, as this slows the response.

Excessive humidity may limit the ability of the meter to read extremely low light levels. In the event that this occurs keep the meter in a warm dry place for 24 hours and performance will be recovered.

FILM SPEED

The film speed selection provides for a range of different film speeds from 32 ASA to 1600 ASA. For film speeds not in this range, allowance must be made or the exposure settings adjusted accordingly.

HOLD buttons

Pressing either of the HOLD buttons memorises the current brightness in that storage location irrespective of whether the INPUT control is in the ON, HOLD 1 or HOLD 2 positions.

The HOLD functions memorise the brightness not the display – the displayed value is adjusted according to the prevailing settings of the exposure, range and film speed settings.

The memories will hold the measured brightness within the specified accuracy of $\pm\frac{1}{3}$ step for a minimum of one hour.

The HOLD functions do not memorise the brightness when the meter is turned off and initialise on power-on in the region of 1 second exposure equivalent.

CARE OF YOUR PHOTOMETER

The Photometer 2 is a sensitive electronic instrument with delicate components and should be treated with care. If handled appropriately, it should give a long and reliable life.

Excessive humidity can affect the ability of the meter to read very low light levels. If this is experienced leave the meter in a warm dry room for 24 hours.

Avoid contact with water. If water enters the unit, we recommend removing the battery then carefully unscrewing the four case screws at the rear of the case to remove the case rear. Leave the case open in a dry room for 24 hours until fully dried out. Carefully replace the rear cover being careful not to damage or trap any wires in the case. If problems persist please contact us for service.

Avoid exposure to temperature extremes. If the metering probe becomes warped (for example if exposed to high temperatures on being left in a car) allow to cool then lay flat and weight it down on a flat surface until straightened.

Avoid exposing the sensor probe to direct sunlight as this can result in excessive power consumption when the unit is on, and may temporarily slow down the response of the sensor to very low light levels. If readings are needed in very low light levels (several minutes to hours of exposure time) it is wise to allow the sensor probe a minute or two to adjust to the dark conditions if it has been exposed to bright light .

The meter may be cleaned with a soft damp cloth if necessary. Avoid getting water in the unit around the push-button switches and connector socket.

If the meter does not function then:

- If there is no function at all and the power-on indicator does not flash, check the battery is inserted correctly and/or try a new battery
- If the meter indication goes to extreme position when switching on, and does not appear to respond to the controls or changes in illumination, check the cable is correctly inserted into both the meter and the sensor probe. If the problem persists and damage to the cable is suspected, try another cable (the connection cable is a standard 3.5mm stereo jack cable)

Please contact us if other problems occur with your meter.

TECHNICAL AND PERFORMANCE DATA

The information contained in this section is for guidance only and represents typical, rather than the guaranteed minimum performance. It is provided for the guidance of specialist users with unusual applications and may be disregarded by the majority of users.

Calibration

The meter has been calibrated to give a negative tone in the centre of the useable range. Film tests have been carried out to determine the optimum point. See figure.

Note that the film base is not perfectly transparent and typically transmits around 50% of the light. The test data has been adjusted accordingly, to give 0% for the lightest possible (around 50% transmission) negative and 100% for a completely opaque negative.

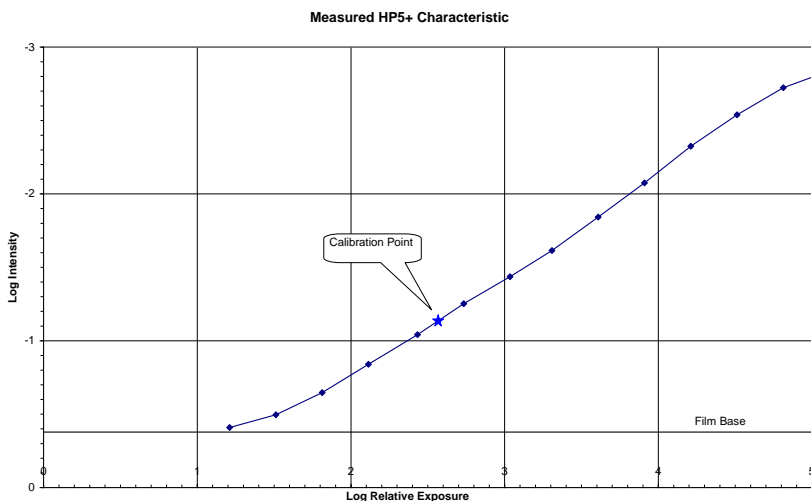

Spectral Response

Peak response is at 530nm (green). Response at extremes of the spectrum will be within a factor of two (one stop). In practice in normal situations, where highly saturated colours at the extremes of the visible spectrum are not normally present, no correction factor need be applied for colour.

WARRANTY, SERVICING, REPAIRS AND ENQUIRIES

The meter is guaranteed against manufacturing defects for a period of one year. Register with us by emailing us with your contact details, quoting your meter serial number (found inside the battery compartment) to extend your warranty to three years.

In the event of damage or defects, please contact us at enquiries@dlgelectronics.com, or write to us at DLG Electronics, 138 Osmaston Road, Derby DE1 2RF, UK, or contact your local distributor. For units outside warranty we can offer cost-effective repair, refurbishment or replacement with a refurbished model if you return your damaged unit. Please do not send us your meter until you have contacted us.

We welcome any feedback, comment or suggestions on our products. Please contact us at enquiries@dlgelectronics.com or use the feedback form on our website dlgelectronics.com.

SPECIFICATION

Exposure Range:	1/2000 second to >1 hour at 125 ASA
Film Speed settings:	32, 40, 50, 64, 80, 100, 125, 160, 200, 400, 800, 1600 ASA (16, 17, 18, 19, 20, 21, 22, 23, 24, 27, 30, 33 DIN)
Display Range	± 6 stops either side of selected setting.
Accuracy:	± 1/3 stop* (1/s, s and m ranges only)
"Hold" duration:	1 hour minimum.
Peak Spectral Response:	530 nm
Power consumption:	3 mA approx
Battery type	6LR61 / 1604A / PP3
Battery reverse connection protection:	Yes
Settling time:	<1s, exposures 1/2000s to 1s at 125 ASA <10s, exposures 1s to 1 min at 125 ASA <1min, exposures 1 min to 1 hr at 125 ASA Up to 10 minutes, exposure times 1 hr to 24 hr at 125 ASA
Sensor	Resistance
Weight	12 oz. approx
Dimensions:	Meter Unit: 4½" x 6" x 1⅝" Metering Probe: 12" x 3/4" x 1/8" approx Frame: - to suit camera format.

Document reference DLG-PM2-001 v6

Applicable to Photometer 2 serial number 024 onwards

© DLG Electronics 2019